

## myCOM 1MCPDAB

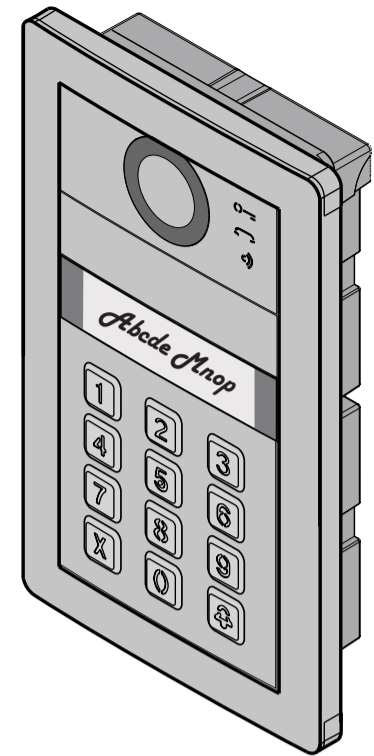

Mi 2553

### ALBA AB3G + PD2100AB

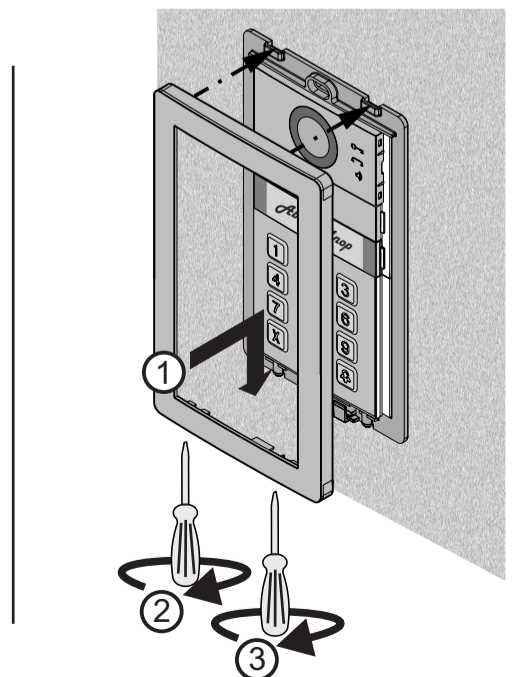
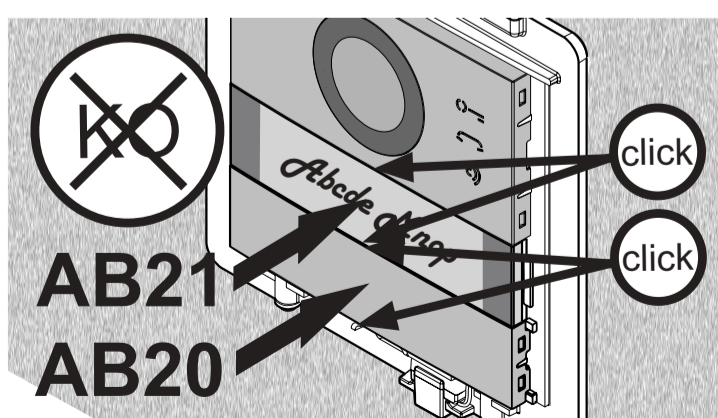
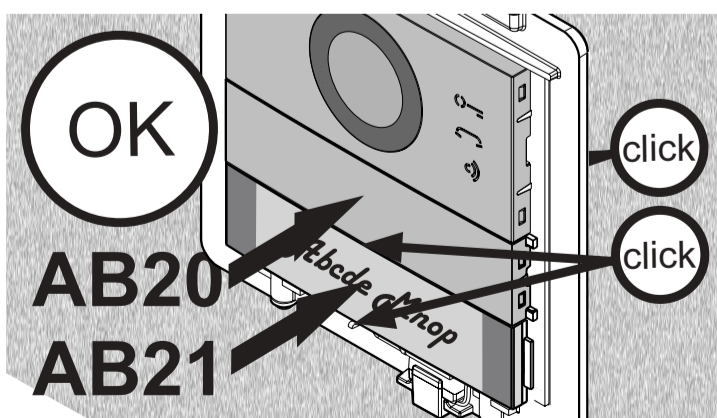
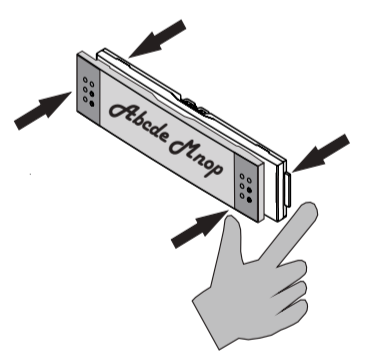
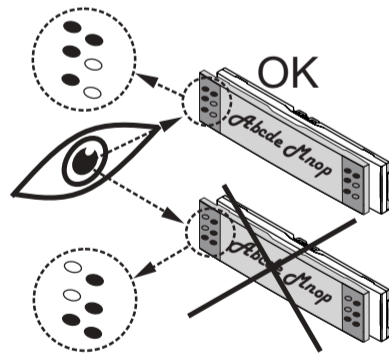
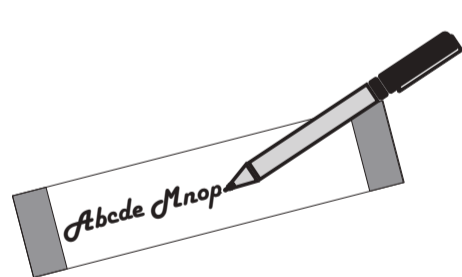
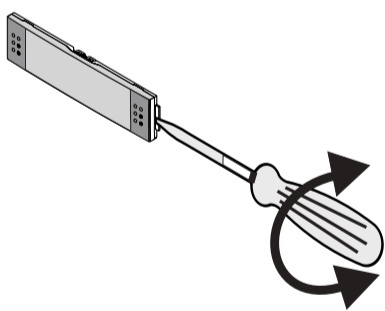
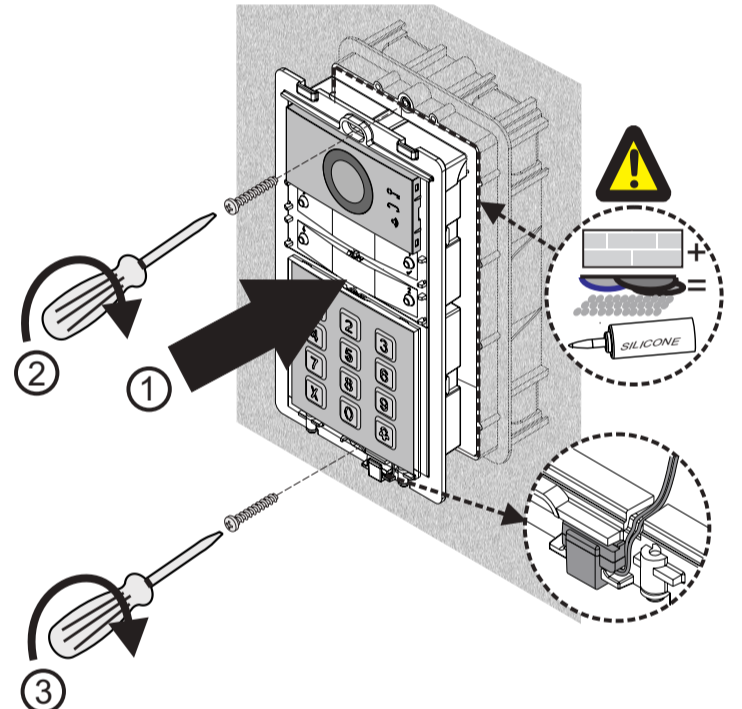
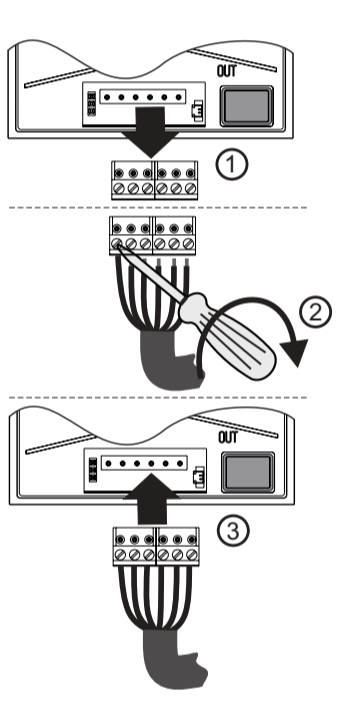
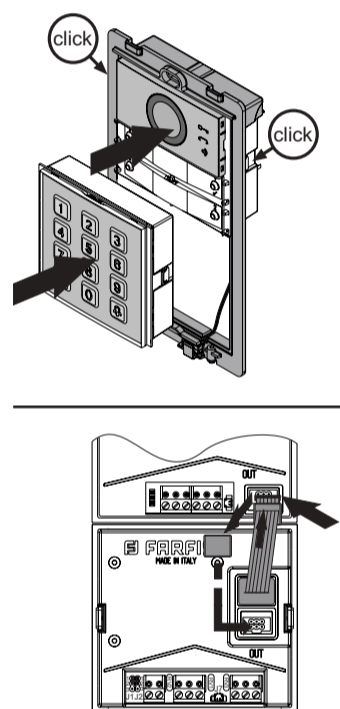
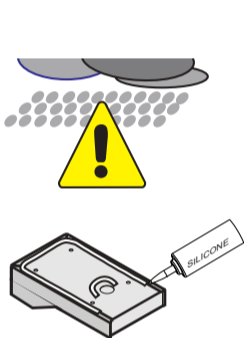
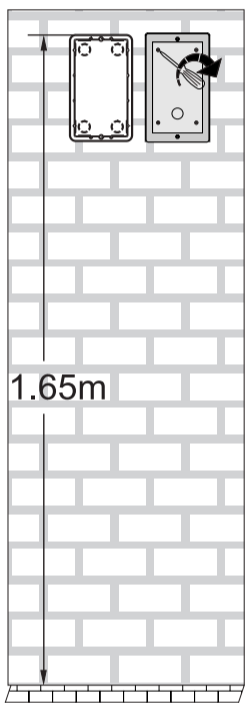

# AB3G + PD2100AB

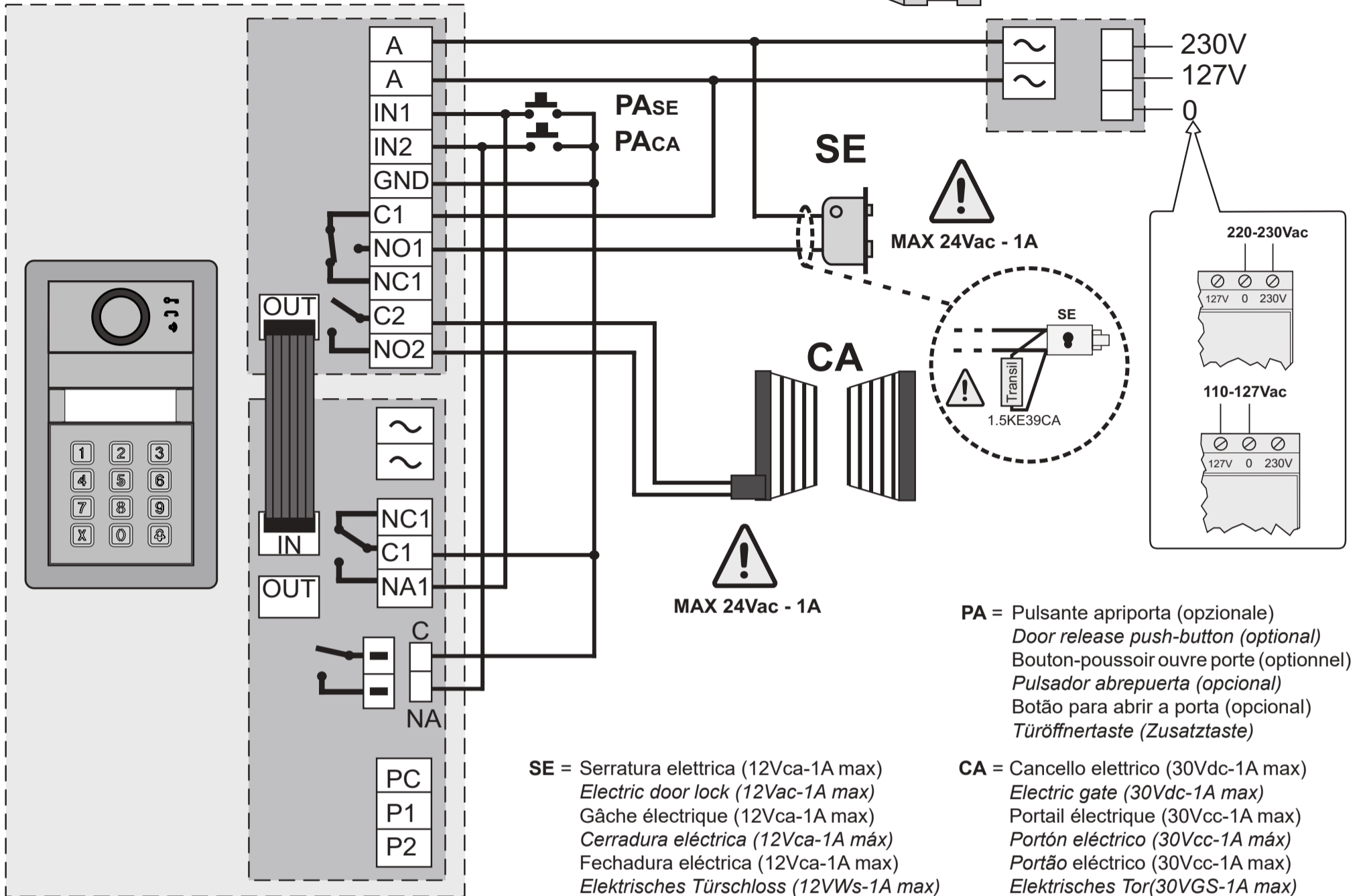

- Per ulteriori informazioni consultare il sito:
- For more information, visit:
- Pour plus d'informations, visitez:
- Para obtener más información, visite:
- Para obter mais informações, visite:
- Für weitere Informationen, besuchen Sie:

[www.farfisa.com/kit/1mcpdab/](http://www.farfisa.com/kit/1mcpdab/)

**ACI srl Farfisa**  
Via E. Vanoni, 3 • 60027 Osimo (AN) • Italy  
Tel: +39 071 7202038  
Fax: +39 071 7202037  
web site: [www.farfisa.com](http://www.farfisa.com)  
e-mail: [info@farfisa.com](mailto:info@farfisa.com)



**Directive 2012/19/EU (WEEE-RAEE)**

Smaltire il dispositivo secondo quanto prescritto dalle norme per la tutela dell'ambiente.  
Dispose of the device in accordance with environmental regulations.  
Écouler le dispositif selon tout ce qu'a été prescrit par les règles pour la tutelle du milieu.  
Eliminar el aparato según cuánto prescrito por las normas por la tutela del entorno.  
Disponha do dispositivo conforme regulamentos ambientais.  
Werden Sie das Gerät in Übereinstimmung mit Umweltregulierungen los.



Mi 2553  
Cod. M527058100